

## Undercounter Dishwasher

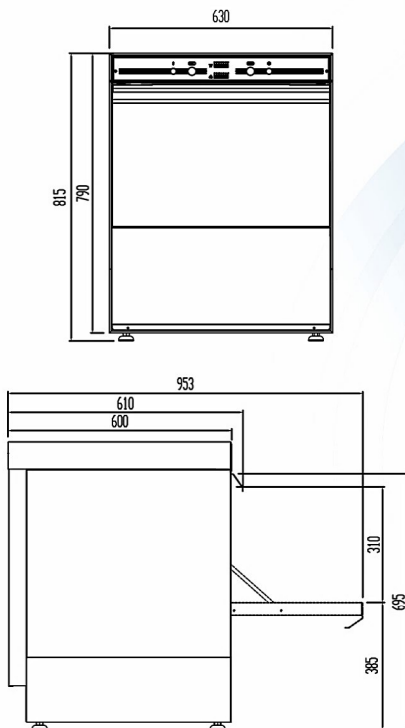

### VT-U50

Description	Undercounter
External Dimensions	630 x 610 x 815mm
Rack Size	500 x 500mm
Max Loading Height	310mm
Washing Cycle Time	90-180sec
Capacity	30 racks/hr
Tank Capacity	33L
Boiler Capacity	5L
Wash Tank Heater	3kW
Booster Heater	4.5kW
Wash Pump Power	0.6kW
Total Power	8.1kW
Power Supply	415V/50Hz/3ph 220V/50Hz/1ph
Inlet Water Pressure	0.5-2.0 kg
Max. Temp of Inlet Water	50 °C
Max. Water Consumption/hr	100L
Water Consumption per cycle	2.5L
Water Inlet (in)	¾"
Drain Outlet (mm)	40mm
Net Weight	50kg

### Features

- Easy operation with only two control buttons
- Two changeable washing cycles
- Default settings for 10-15 seconds rinsing cycle
- Micro switch to stop operation should the door open
- Machine structure is made of SUS304/QN1803 stainless steel for durability with anti rat design

